

- Compact and simple low-cost type
- Housing of extruded aluminium sheath
- Flexible stainless steel cable Ø 1 or 1,2 mm
- Strong spring mechanics
- Precision cable drum



## Inkrementaler Weggeber PLE 85 / PLE 115

Linear Motion Transducer up to 15.000 mm range, with Standard Incremental Encoder ED 58

### Used encoder

**Used encoder**  
Standard Encoder ED 58

### Type explanation

#### PLE 85-25-12/ED58-6-8192-05-D-RC12

Measuring range	25 = 2.500 mm 50 = 5.000 mm 75 = 7.500 mm 100 = 10.000 mm 150 = 15.000 mm
Encoder type	Incremental
Number of channels	3 = A + B + M 6 = AA + BB + MM
Resolutions	xxxx = Impulse pro Umdrehung
Supply voltage	05 = 5 VDC ± 5% 30 = 10..30 VDC
Output driver	D-RS422 P
Position of connection	R S
Connector	C07 = 7 pins Binder C12 = 12 pins M23 M10 = 10 pins MIL

## Technical data

### Mechanical data

Acceleration of cable	$\leq 30 \text{ ms}^{-2}$ (PLE115-100, PLE115-150) $\leq 50 \text{ ms}^{-2}$ (PLE85-25, PLE115-50) $\leq 60 \text{ ms}^{-2}$ (PLE115-75)
Side movement of cable	$\leq 3^\circ$
Weight	$\approx 1,3 \text{ kg}$ (PLE 85) $\approx 1,7 \dots 3,7 \text{ kg}$ (PLE 115)

### Environmental conditions

Vibration	$200 \text{ ms}^{-2}$ (20 ... 2000 Hz)
Shock	$500 \text{ ms}^{-2}$
Operating temperature	0 ... +80°C
Storage temperature	-40 ... +80°C
Atmospheric humidity	$\leq 95\%$ r.h.
Protection class	IP 65 (Standard Encoder ED 58) IP 40 (Mechanic of Linear Motion Transducer)

### Electrical data

Scanning type	Optical, without contact
Transmitter, infrared	LED
Receiver	Photo-Array
Supply voltage	$V_{cc} = 5 \text{ VDC} \pm 5\%$ $V_{cc} = 10 \dots 30 \text{ VDC}$
Power consumption	200 mA max.
Output frequency	$\leq 300 \text{ kHz}$ (Output D) $\leq 160 \text{ kHz}$ (Output P)
Signal level	High $> V_{cc} - 2 \text{ V}$ Low $< 0,5 \text{ V}$
Load capacity of the outputs	20 mA

## Cable

Wire colour	Signal
Brown 0,5 mm <sup>2</sup>	+Vcc
Blue	+Vcc Sense <sup>1)</sup>
White 0,5 mm <sup>2</sup>	0 V GND
White	0 V Sense
Brown	Signal A+
Green	Signal A- <sup>2)</sup>
Grey	Signal B+
Pink	Signal B- <sup>2)</sup>
Red	Signal M+
Black	Signal M- <sup>2)</sup>
Shield	N.C.

1) nur bei Vcc = 5 VDC TTL

2) nur bei 6 Ausgangskanälen

## Connector 7 pins Binder

Connection	Signal
Pin 1	0 V GND
Pin 2	N.C.
Pin 3	Signal A
Pin 4	Signal B
Pin 5	+Vcc
Pin 6	Signal M
Pin 7	Shield

## Connector 12 pins M23

Connection	Signal
Pin 1	Signal B- <sup>1)</sup>
Pin 2	+Vcc Sense <sup>2)</sup>
Pin 3	Signal M+
Pin 4	Signal M- <sup>1)</sup>
Pin 5	Signal A+
Pin 6	Signal A- <sup>1)</sup>
Pin 7	N.C.
Pin 8	Signal B+
Pin 9	Shield
Pin 10	0 V GND
Pin 11	0 V Sense
Pin 12	+Vcc

1) nur bei 6 Ausgangskanälen

2) nur bei Vcc = 5 VDC TTL

## Connector 10 pins MIL

Connection	Signal
Pin A	Signal B+
Pin B	Signal A+
Pin C	Signal M+
Pin D	+Vcc
Pin E	+Vcc Sense
Pin F	0 V GND
Pin G	Shield
Pin H	Signal B- <sup>1)</sup>
Pin I	Signal A- <sup>1)</sup>
Pin J	Signal M- <sup>1)</sup>

1) nur bei 6 Ausgangskanälen

## Output driver

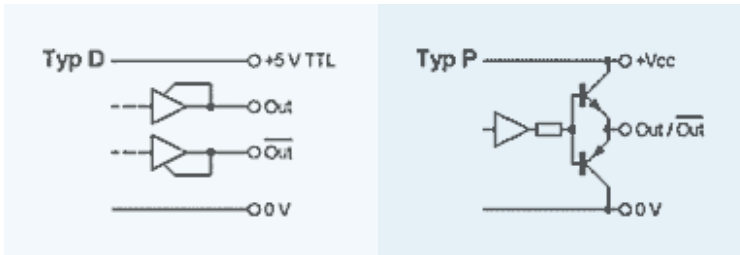

## Outline drawing

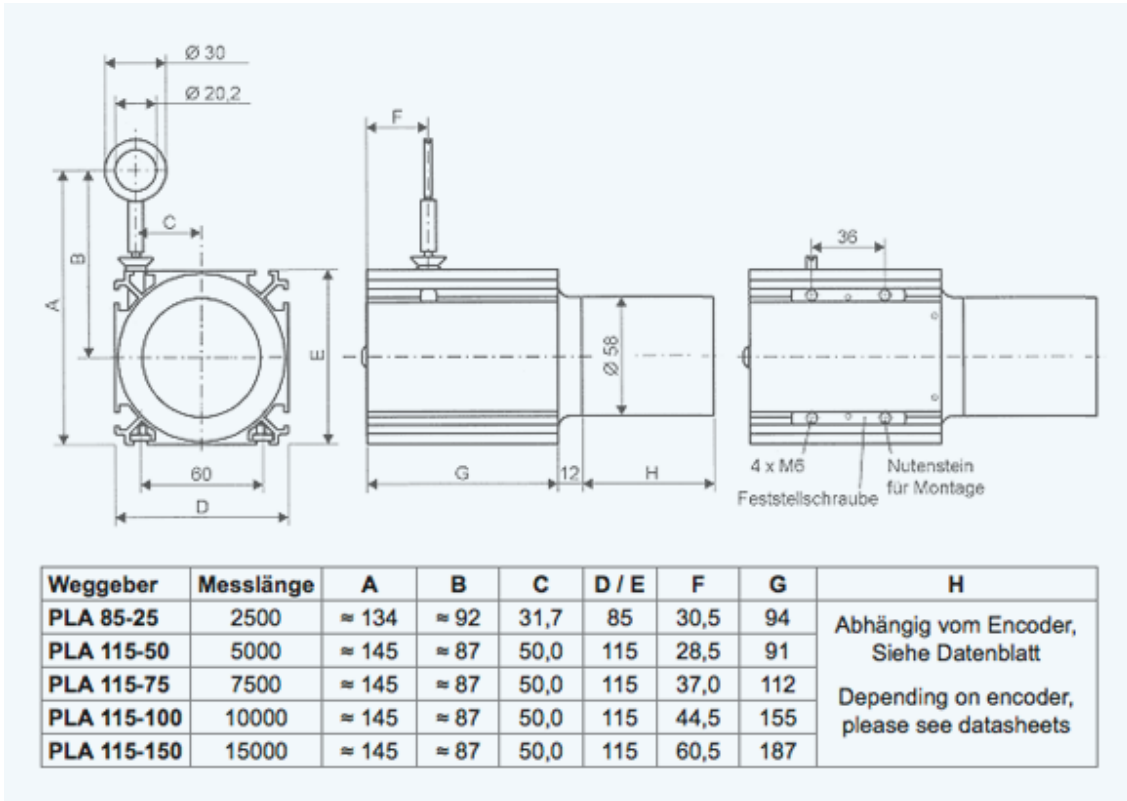

Version ZE 612-411 · Subject to change

INDUcoder® · INDUcoder Messtechnik GmbH, Kaiserstraße 316, 47178 Duisburg, Deutschland  
 Tel: (0203) 57047-0, Fax: (0203) 57047-20, E-Mail: [info@inducoder.de](mailto:info@inducoder.de), Internet: [www.inducoder.de](http://www.inducoder.de)