

Stainless steel housing
 Protection IP 67
 Compact design Ø 100 mm x 120 mm



Robust Encoder AWG 102 / EAS 57

Optical absolute encoder AWG102 with through shaft for impartment of rotation

Resolution

Resolution (Steps/360°):

4096 = 12 bit

8192 = 13 bit

65536 = 16 bit

Measuring range

Measuring range

Single-Turn

1 turn

Type explanation

AWG102 EAS57-8192G-30-D-SMS

Robust Encoder	AWG102
Stainless steel housing	Yes
Encoder type	Absolute
Flange diameter	Ø 100 mm
Case diameter	Ø 100 mm
Number of bits	4096 = 12 bits 8192 = 13 bits 65536 = 16 bits
Single-turn	Yes
Supply voltage	30 = ..30 VDC
Output driver	D-SSI P
Position of connection	S
Connector	C12 = 12 pins M23 C16 = 16 pins M23 M10 = 10 pins MIL
Shaft diameter	Ø 10 mm

Technical data

Mechanical data

Rotational speed	? 5000 min ⁻¹
Breakaway torque	? 20 Ncm
Loading of bearings	1500 N radial 1000 N axial
Angular acceleration	? 5 x 10 ⁵ rad/sec ²
Weight	? 5,5 kg
Case	Stainless steel 1.43.01 / AISI 304
Sealings	Viton

Environmental conditions

Vibration	200 ms ⁻² (50 Hz / 1h)
Shock	500 ms ⁻² (11 ms)
Operating temperature	-20 ... +70°C standard -40 ... +125°C optional
Atmospheric humidity	? 95% r.h.
Protection class	IP 67 (DIN 40050/IEC 144)

Electrical data

Scanning type	Optical, without contact
Transmitter, infrared	LED
Receiver	Photo-Array
Scanning frequency LSB	800 kHz ±½ LSB (12 bit) ± 1 LSB (13 bit) ± 2 LSB (16 bit)
Supply voltage	V _{cc} = 10...30 VDC
Power consumption	? 100 mA (V _{cc} = 24 V)

Electrical connections

SSI

Interface	RS485 Clock and Data
Clock	67 kHz - 1,6 MHz

Push-pull parallel

Output frequency	< 820 kHz
Signal level	High > V _{cc} - 3 V (I _{out} = 30 mA) Low < 0,4 V (I _{out} = 10 mA) Low < 2,0 V (I _{out} = 30 mA)
Load capacity of the outputs	30 mA

Inputs

Rotational direction	CW = High > 0,7 x V _{cc} CCW = Low > 0,3 x V _{cc}
----------------------	--

AWG options

Electrical heating

Temperature control	Thermostat +5° / +15°C
Power consumption	18 W (12 V / 1,5 A) 72 W (24 V / 3,0 A)

Forced-air cooling

Pressure reducing valves	1 bar, input and output
--------------------------	-------------------------

Cable

Wire colour	Signal
Brown 0,5 mm ²	+Vcc
White 0,5 mm ²	0 V GND
Blue	Clock+
White	Clock-
White/Brown	Data+
Yellow	Data-
Brown	CW/CCW
Green	RESET ¹⁾
Shield	N.C.

1) optional

Connector 12 pins M23

Connection	Signal
Pin 1	+Vcc
Pin 2	0 V GND
Pin 3	Clock+
Pin 4	Data+
Pin 5	RESET ¹⁾
Pin 6	Data-
Pin 7	Clock-
Pin 8	N.C.
Pin 9	CW/CCW
Pin 10	N.C.
Pin 11	N.C.
Pin 12	N.C.

1) optional

Connector 10 pins MIL

Connection	Signal
Pin A	Clock+
Pin B	Data+
Pin C	RESET ¹⁾
Pin D	+Vcc
Pin E	N.C.
Pin F	0 V GND
Pin G	Clock-
Pin H	Data-
Pin I	CW/CCW
Pin J	N.C.

1) optional

Connector 12 pins M23

Connection	Signal
Pin 1	G 0 / 2 ⁰
Pin 2	G 1 / 2 ¹
Pin 3	G 2 / 2 ²
Pin 4	G 3 / 2 ³
Pin 5	G 4 / 2 ⁴
Pin 6	G 5 / 2 ⁵
Pin 7	G 6 / 2 ⁶
Pin 8	G 7 / 2 ⁷
Pin 9	G 8 / 2 ⁸
Pin 10	G 9 / 2 ⁹
Pin 11	G 10 / 2 ¹⁰
Pin 12	G 11 / 2 ¹¹
Pin 13	CW/CCW
Pin 14	G 12 / 2 ¹² oder STORE ¹⁾
Pin 15	+Vcc
Pin 16	0 V GND

1) G12/2¹² bei 13 Bit, STORE bei Binär-Code, sonst N.C.

Output driver

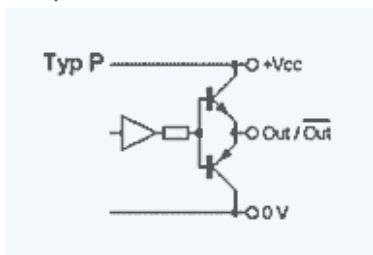

Outline drawing

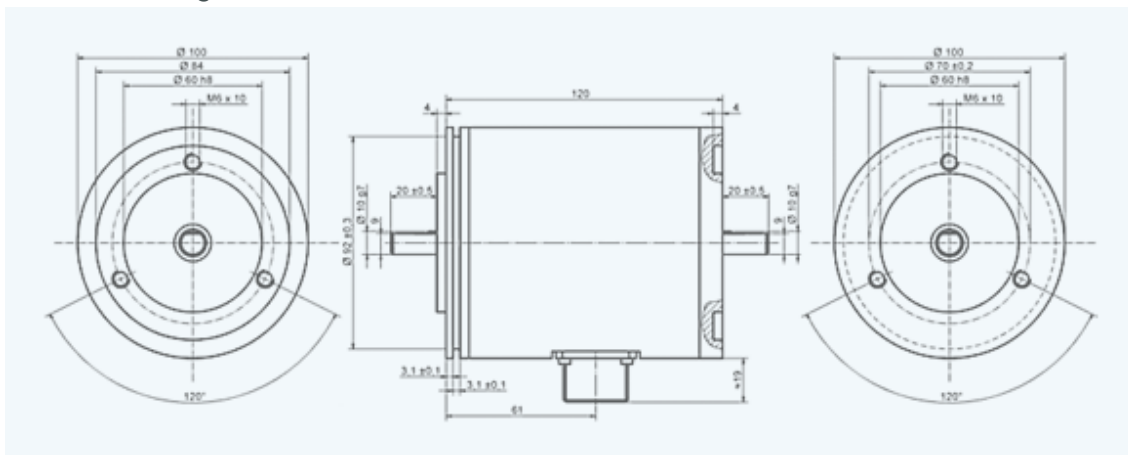

Version AE 619-607 · Subject to change

[Go back](#)

INDUcoder® · INDUcoder Messtechnik GmbH, Kaiserstraße 316, 47178 Duisburg, Deutschland
 Tel: (0203) 57047-0, Fax: (0203) 57047-20, E-Mail: info@inducoder.de, Internet: www.inducoder.de