



- Solid mechanical construction
- Protection to IP 65, IP 66
- SMD technology
- Electronic preset
- Programmable



Absolut Manual Encoder MEA 70 Profibus / CANopen[®] / Device Net

Manual pulse generator with magnetic click-stop with programmable Absolute Encoder, Single-turn or Multi-turn

Resolution

Resolution (Steps/360°):

4096 = 12 bit

8192 = 13 bit

65536 = 16 bit

Measuring range

Measuring range

Single-Turn

1 turn

Multi-Turn

4096 Umdrehungen = 12 bit

16384 Umdrehungen = 14 bit

Type explanation

MEA70 /EAM58-24B-30-PB

Encoder type	Absolute
Case diameter	∅ 58 mm
Number of bits	12 = 12 bits x 1 turn 13 = 13 bits x 1 turn 16 = 16 bits x 1 turn 24 = 12 bits x 4096 turns 25 = 13 bits x 4096 turns 28 = 16 bits x 4096 turns 26 = 12 bits x 16384 turns 27 = 13 bits x 16384 turns 30 = 16 bits x 16384 turns
Single-turn	Yes
Multi-turn	Yes
Supply voltage	30 = 10..30 VDC
Interface	PB = Profibus CO = CANopen® DN = Device Net

Technical data

Mechanical data

Graduation	1 - 100
Torque	5 .. 20 Ncm
shaft loading	? 50 N radial ? 20 N axial
Operational life of ball bearings	> 6 x 10 ⁹ revolutions
Weight	? 1,5 kg

Environmental conditions

Vibration	100 m/s ² (10 ... 1000 Hz)
Shock	300 m/s ² (11 ms)
Operating temperature	-40 ... +85°C
Storage temperature	-40 ... +85°C
Atmospheric humidity	? 98% r.h.
Protection class	IP 65 (DIN 40050/IEC 144) IP 66 (optional)

Electrical data

Scanning type	Optical, without contact
Transmitter, infrared	LED
Receiver	Photo-Array
Scanning frequency LSB	800 kHz
Measurement accuracy	±½ LSB (12 bit) ± 1 LSB (13 bit) ± 2 LSB (16 bit)
Supply voltage	V _{cc} = 10...30 VDC
Power consumption	? 100 mA (V _{cc} = 24 V)

Electrical connections

Profibus

Interface	RS485 with optocoupler
Clock	max. 12 MBaud

Outline drawing

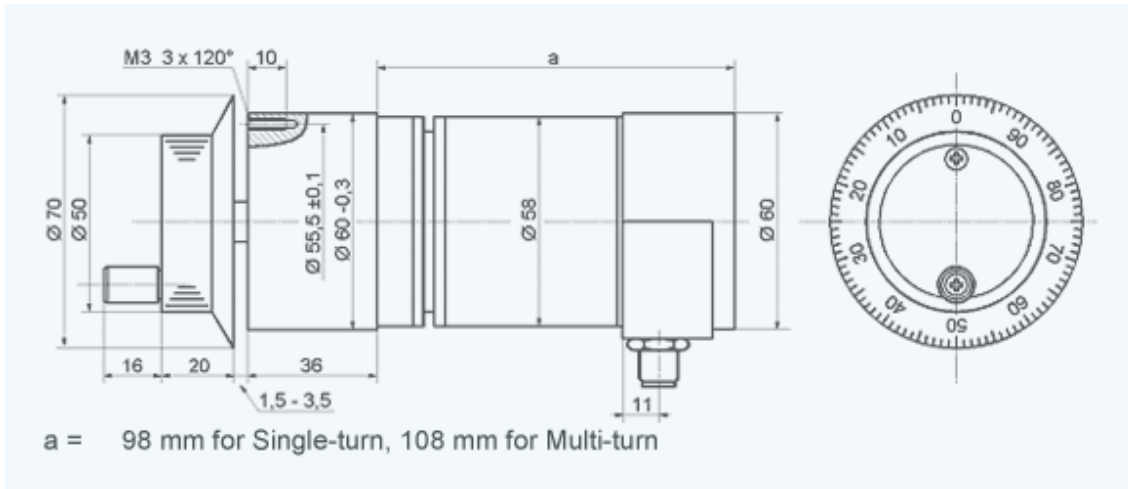

Version MA 401-611 · Subject to change

[Go back](#)

INDUcoder® · INDUcoder Messtechnik GmbH, Kaiserstraße 316, 47178 Duisburg, Deutschland
Tel: (0203) 57047-0, Fax: (0203) 57047-20, E-Mail: info@inducoder.de, Internet: www.inducoder.de